

# Simple Buffered Splitter

FRW - October 2010

This is a very simple buffered splitter project. You can use it to create two equal outputs for your guitar or another pedal. This is handy for running a stereo amplifier setup, splitting a single signal into two effects pedals, or any of several other applications in which you need to have two equal, buffered outputs.

The circuit consists of a simple transistor input buffer that feeds a pair of parallel op amp-based output buffers. This is NOT a passive splitter or A/B box.

Input impedance is approximately 500K. If you need higher input impedance, increase the value of R1 and R2. To calculate the resulting impedance, use the formula for resistors in parallel. Example: If you want input impedance of 1M, use a pair of 2M resistors for R1/R2.

PCB dimensions are (approximately): 1.28" wide x 0.9" high.

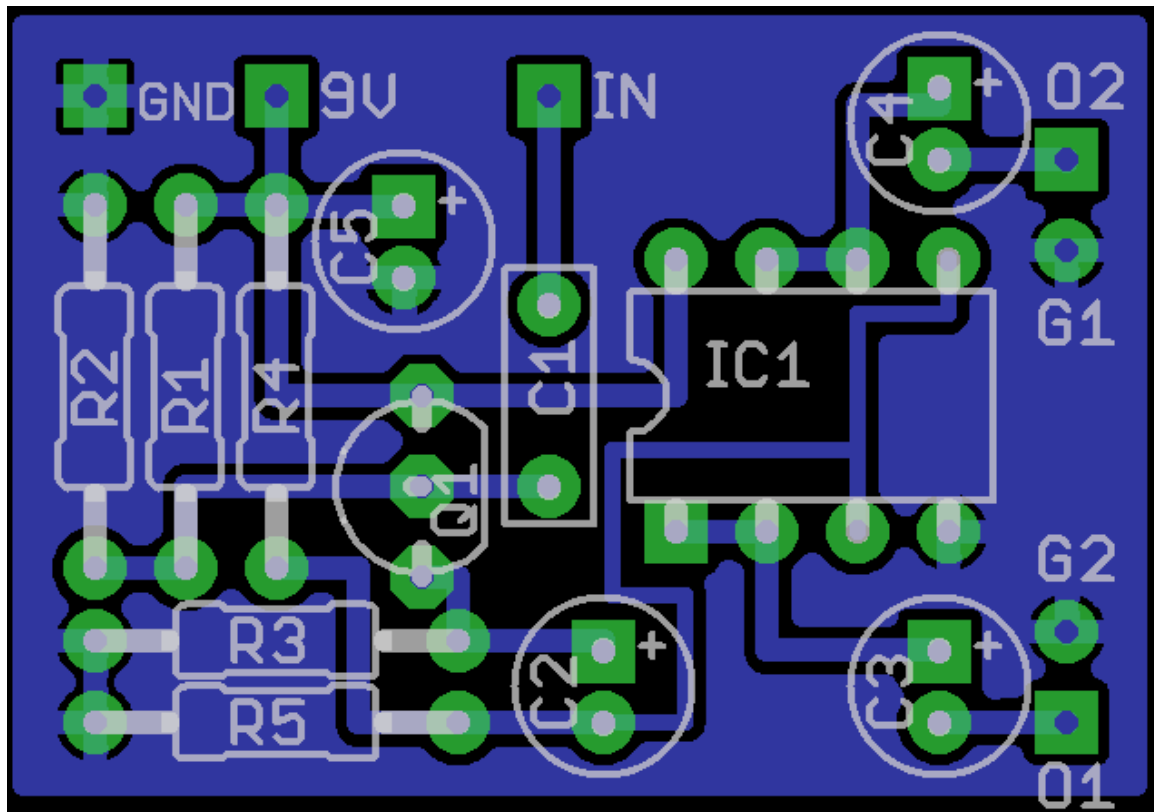

## Parts List

C1	100n
C2	10uf
C3	10uf
C4	10uf
C5	100uf
IC1	TL072*
Q1	MPSA18
R1	1M
R2	1M
R3	3K3
R4	10M
R5	10M

\* Other dual op amp packages will also work.

For a fully built working splitter pedal, you will also need:

- 3 mono 1/4" audio jacks (one for input, two for output)
- 9V DC jack
- LED, mounting bezel, and current-limiting resistor (all optional)

## Wiring Notes

- O1 and O2 are the output pads.
- G1 and G2 are additional ground pads. These can be used to ground the two output jacks. You do not have to use these pads, but they may be handy depending on how your pedal is laid out.

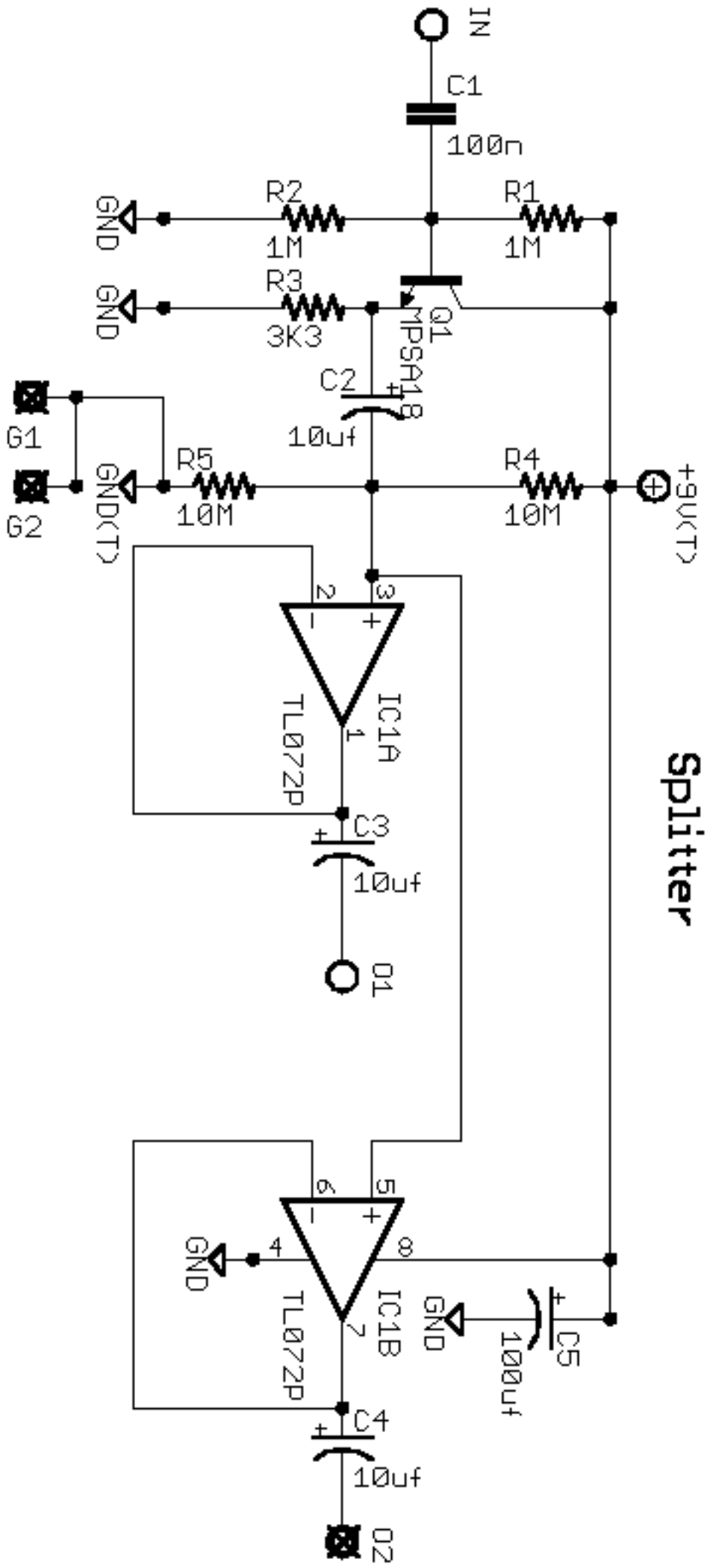

# Splitter

